

Dissolved Oxygen Monitor

Model Q46D



Top Right: Optical Sensor

Bottom Left: Galvanic Membrane Sensor

Dissolved Oxygen Monitoring is critical to stable operation of biological processes in wastewater treatment plants. Whether it be fine bubble aeration, coarse bubble aeration, surface aeration, or brush aerators, maintaining the proper D.O. level will produce better results. The Q46D is ideal for control applications where reliable performance is required 365 days a year.

*Improve Performance &
Reduce Maintenance Costs*



INTRODUCTION.

Dissolved Oxygen monitoring is critical for aeration system process control. Optimization of the biological process, whether it's removal of organic material, nitrification, or nitrification/denitrification, depends on maintaining proper D.O. levels. Controlling air flow to within the optimal range eliminates excess aeration, which translates into significant energy savings.

ATI's Model Q46D Dissolved Oxygen Monitor is designed to provide reliable oxygen measurement and help reduce operating costs. Two types of sensing technologies are available for use with the Q46D system: Membraned Electrochemical and Optical (fluorescence). Both sensors will provide reliable long-term performance with minimal maintenance. No hardware modifications are required to change from one sensor type to the other. The monitor can be configured for AC or DC power supplies, and a portable battery-powered unit is available to meet a variety of monitoring needs.

When process conditions require frequent sensor cleaning, our unique Q-Blast Auto-Cleaner can be used to keep the system operating nearly maintenance free. This time-proven system has been instrumental in providing years of worry free operation.

Q46D Monitors provide the *Flexibility You Need* for Any Application

FEATURES.

Sensor Options. Choice of using either optical or galvanic membraned sensors. Electronics handle either sensor option without adjustments or special programming.

Auto-Cleaning. Automatic "Air Blast" sensor cleaning system available for reducing maintenance in applications where sensor fouling is a problem.

Cal Check. Automatic calibration check at the end of an auto-clean cycle ensures sensor is clean and responding to changing oxygen concentration.

AC or DC Power Options. Power options include universal 90-260 VAC or 12-24 VDC.

Analog Output Options. Two isolated 4-20 mA outputs are standard, with an option for a third output if required. Default setting provides analog outputs for D.O. and temperature.

PID Output. Standard PID control function assignable to one analog output.

Digital Communications. Three digital communication protocols are available: Profibus DP Modbus RTU or Ethernet IP.

Relay Outputs. Three SPDT relays are standard, with relay functions programmable for alarm, control, or trouble indication. An additional three internal low-power relays provide control of the automatic sensor cleaning function.

Flexible Mounting. NEMA 4X (IP-66) enclosure is suitable for wall, pipe, or panel mounting.

Clear Display. Back-lit large LCD display provides clear visibility in any lighting conditions. A scrolling second line on the display provides additional information and programming prompts.

AUTOMATIC SENSOR CLEANING.

While both sensor types are capable of providing reliable dissolved oxygen readings, neither will function reliably unless the face of the sensor is kept clean. Over time, the treatment process deposits a biologically active film onto the surface of the sensor which impedes the transfer of oxygen. This build up can cause sluggish response to changing oxygen concentrations and inaccurate oxygen values. The removal of this film, and other solids that may adhere to the sensor, is critical to the integrity of the oxygen readings. Sensor cleaning can be performed manually, but it's time consuming and often neglected when other maintenance needs take precedence.

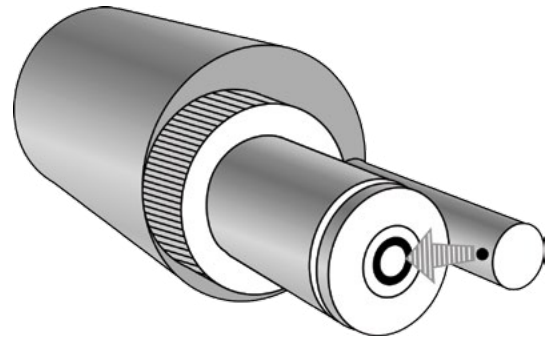

Trust the Original Air-Blast System.



Q-Blast

ATI's Q-Blast option provides the ideal answer for automatic Dissolved Oxygen sensor cleaning. Employing a unique "air-blast" cleaning method, sensors can be cleaned as often as necessary without operator attention. Pulses of pressurized air delivered through a nozzle at the tip of the sensor remove accumulated solids from critical sensing surfaces, resulting in accurate and reliable measurements.

The Q-Blast Auto-Clean assembly is housed in a NEMA 4X enclosure suitable for indoor or outdoor use. The system includes an integral compressor and air-pulse control components, with a power supply for the entire air supply system incorporated into the design. A simple connection to the Q46D monitor provides the sequencing for the system and allows the operator to select cleaning frequencies as often as once every hour to as little as once every 999 hours. To insure performance in extreme cold conditions, a thermostatically controlled heater is included in the assembly, allowing operation down to -40°C.

A *Blast* of Air
keeps the
Auto-Clean
Sensor
Clean!



Auto-Clean System with Integral Air-Blast

OPTICAL SENSOR.

The optical DO sensor operates on a light-based principle called “fluorescence” which is a type of luminescence. Certain chemical compounds will absorb one type of light energy, and then emit a different type of light energy. This light emission is called luminescence.

The active portion of the sensor has a metal-based compound embedded in a structural matrix. A light source inside the sensor illuminates this compound which absorbs light at a specific wavelength. The compound then emits light at a different wavelength which is picked up by a photodetector within the sensor. As oxygen diffuses into the active sensor material it interacts with the light absorbing compound and interferes with the emission reaction. This interaction, called quenching, causes the light absorbing material to release energy in a form other than light. The degree of quenching is proportional to the concentration of dissolved oxygen. The quenching reaction is reversible, which allows this sensor to measure increasing and decreasing concentrations of oxygen.

Optical Sensor *Reduces* Maintenance



Auto-Clean Optical Sensor

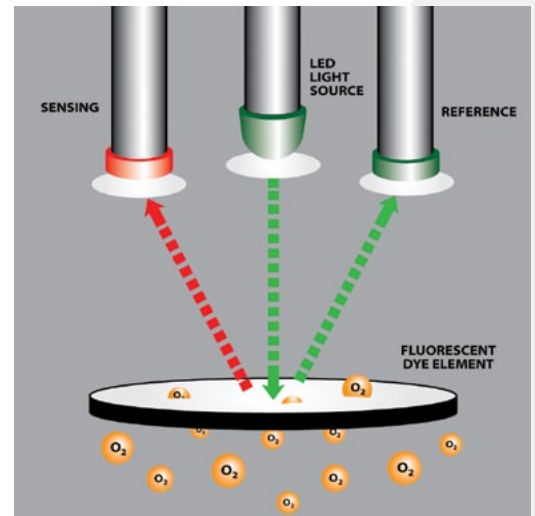

Sensor Operation

Optical sensors do not have internal electrolyte, so maintenance of this type of sensor is limited to changing the optical element. Over time, the element will lose the ability to absorb light due to a process called “bleaching”. With some sensors, this process is greatly accelerated when it is exposed to direct sunlight, and will cause irreversible damage to the sensor element.

ATI’s optical sensor element is designed to last a several years in normal operation. The sensor design allows for exposure to direct sunlight without damaging the sensor element.

OPTICAL SENSOR SPECIFICATIONS

Range	0-40 PPM
Wetted Materials	PVC
Optical Element	Replacement Disk, 2-5 year life
Cable Length	30 ft (9.2 m) standard 200 ft (61 m) max with junction box

Response Time	90% in 3 minutes
Operating Temp.	-5 to 50°C
Size	2.4” D x 5.5” L (6.1 x 14 cm)
Weight	2 lbs (0.9 kg)

GALVANIC MEMBRANED SENSOR.

Membraned type D.O. sensors have been used for D.O. monitoring and control for over 40 years and have proven to be consistently accurate and reliable. Properly designed, a membraned sensor will provide continuous service for a year or more without maintenance of any kind.

Galvanic oxygen sensors function in much the same way as a battery. The sensing elements consist of platinum cathode and lead anode, with a durable Teflon membrane isolating the sensor system from the liquid being measured. Oxygen diffuses through the membrane and is reduced to hydroxide ion on the surface of the cathode. This reaction generates current between the platinum and lead electrodes which is proportional to oxygen concentration. An RTD temperature element measures water temperature and corrects the sensor signal for its effect. The result is a D.O. measurement that's accurate over an operating range of -5-50°C.

OUR SENSOR MAKES SENSE.

Both Standard and Auto-Clean sensors use the same rebuildable D.O. cartridge. A durable 5-mil membrane insures that these sensors perform reliably in the most demanding applications, and a 2-mil membrane is available if faster response is needed. Modular design allows easy removal of the cartridge for service, eliminating the need for membrane changes out on the aeration tank. Spare cartridges can be prepared on the bench and quickly swapped to minimize downtime when service is required. Better yet, sensor cartridges can be rebuilt at very little cost.

The D.O. cartridge holders for both types of sensors contain a preamplifier potted in the holder assembly. This preamp reduces the potential for electrical interference with sensor signals and allows sensor cables to be extended long distances without signal loss.

For applications where measurements need to be made in a closed system, a flow-type D.O. sensor is also available with a number of options for flowcells to meet specific applications. Your ATI representative can assist with your selection.



Standard D.O. Sensor

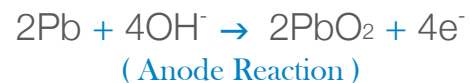
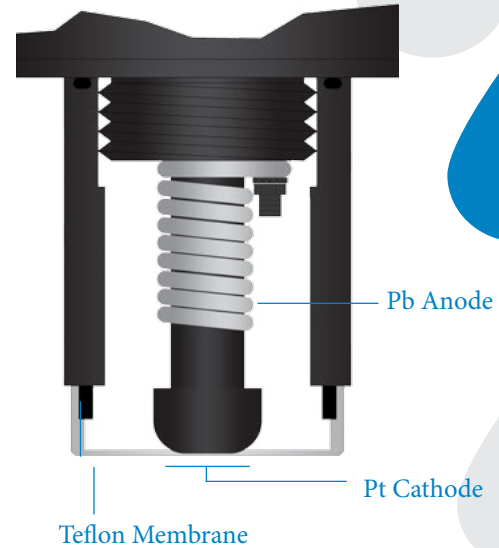

Auto-Clean Sensor

GALVANIC SENSOR SPECIFICATIONS

Range	0-40 PPM
Wetted Materials	Noryl, PVC, & 316SS
Membrane/Response	5 mil - 90% in 3 minutes (standard) 2 mil - 90% in 1 minute (optional)
Cable Length	30 ft. (9.2 m) standard 1000 ft. (307 m) max. with junction box
Operating Temp.	-5 to 50°C
Size (Auto-Clean)	2.4" D x 5.5" L (6.1 x 14 cm)
Weight	2 lbs (0.9 kg)
Size (Standard)	1.8" D x 6" L (cm)

Q46D SPECIFICATIONS

ELECTRONIC MONITOR

Display Range	0 - 40.00 PPM (or mg/L); 0-200% saturation
Accuracy	0.5% of selected range or 0.02 PPM
Repeatability	0.3% of selected range or 0.01 PPM
Non-Linearity	0.1% of selected range
Temperature Drift	0.01% of span/°C
Power	90-260 VAC, 50/60 Hz, 10VA max.; 12-24 VDC, 500 mA max.
Analog Outputs	Two isolated 4-20 mA, 500Ω load max. (3rd output optional)
Relays	Three SPDT, 6A @250 VAC, 5A @24VDC (3 additional SPST non-isolated, 1A @30 VDC optional)
Display	4 digit, 0.75" numeric LCD with 12 character second line, LED back light.
Enclosure	NEMA 4X (IP-66) Polycarbonate, V-0 flammability
Operating Temperature	-20 to 60°C (-4 to 140°F)
Weight	4 lbs. (1.8 kg); Auto-Clean version: 18lbs (8.1 kg)
Sensor Options	Optical Fluorescence Quenching or Membrane-Covered Galvanic (flow type or submersible)

NOTES:

- 1 - All systems with membraned sensors are supplied with one package of membranes, one 120 cc bottle of electrolyte, and one spare parts kit.
- 2 - Pipe mount requires two 2" U-bolts (47-0005).
- 3 - When Auto-Clean option is selected you must also select option 3 in Suffix E.

ALSO AVAILABLE!

For simple D.O. applications that don't require relays, extra outputs, or digital communications, ATI also supplies a Loop-Powered 2-wire transmitter, model Q45D. Using either optical or membraned type sensor, this unit provides a more economical measurement option, especially if multiple sensors are needed.



ORDERING INFORMATION

Model Q46D-A-B-C-D Dissolved Oxygen Monitor

Suffix A - Power

- 1 - 100-240 VAC, +/-10%, 50/60 Hz
- 2 - 12-24 VDC, (requires 300 mA)
- 3 - 90-260 VAC, 50/60 Hz. with Auto-Clean assembly
- 4 - 12 VDC with Auto-Clean assembly (requires 1.0 A)

Suffix B - Sensor Type

- 1 - Submersible sensor with 15 ft cable
- 2 - Submersible sensor with 30 ft cable
- 3 - Auto-Clean sensor with air nozzle and 30 ft cable
- 4 - Auto-Clean sensor with air nozzle and 60 ft cable
- 5 - Flow type Membraned sensor with 25 ft interface cable
(select flowcell from options list)
- 6 - Optical D.O. Sensor with cleaner nozzle, 30 ft (10 m) cable
- 7 - Optical D.O. Sensor with flowcell assembly

Suffix C - Membrane Type

- 1 - 5 mil (standard)
- 2 - 2 mil
- 3 - Not applicable (for optical sensor)

Suffix D - Digital Output

- 1 - None
- 2 - Profibus-DP
- 3 - Modbus-RTU
- 4 - Ethernet-IP

ACCESSORIES

- 00-0628** Submersion mounting bracket kit for standard sensors
- 00-0629** Mounting kit for Auto-Clean sensor with rag shedder
- 07-0100** Junction Box, NEMA 4X
- 31-0038** 7-conductor optical sensor cable, 300 ft max.
- 31-0001** 5-conductor sensor interconnect cable (max. 1000 ft)
- 00-0624** Mounting bracket kit for Auto-Clean sensor
- 45-0043** Pipe adapter for Auto-Clean sensor
- 05-0094** Panel mount bracket kit
- 47-0005** 2" U-bolt, 304SS
- 00-1637** Q-Blast Assembly with Power J-Box and Mounting Rails
- 00-0625** 1-½ flow tee assembly
- 00-0043** Constant-head flowcell
- 00-1522** Sealed flowcell



Represented by:



New South Wales and
Australian Capital Territory
+61 2 4350 8200
Victoria
+61 3 9325 3900

Northern Territory
and South Australia
+61 8 8374 7800
Western Australia
+61 8 9412 6100

Queensland
+61 7 3802 9500
sales@trility.com.au

Tasmania
+61 3 6391 7300