

Pressure reducing valve type 582 PVC-U
Unions with solvent cement sockets ASTM
Without manometer

Model:

- Diaphragm PTFE/EPDM
- Integrated stainless steel mounting inserts
- 0.5-9.0 bar (7-130 psi)

0.3-3.0 bar (4-44 psi) on request
 Manometer on request

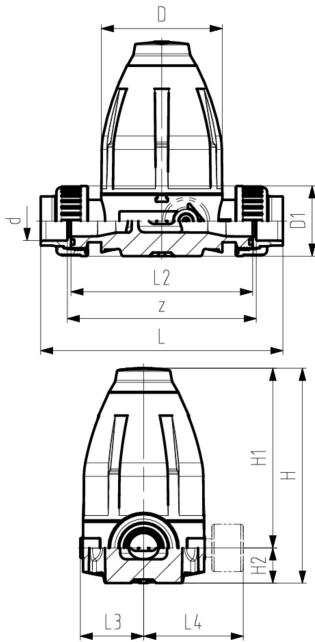

DN (mm)	PN (bar)	O-rings EPDM Code	O-rings FKM Code	Weight (kg)	SP	GP
15	10	161 582 202	161 582 212	0.700	1	0
20	10	161 582 203	161 582 213	1.490	1	0
25	10	161 582 204	161 582 214	1.520	1	0
32	10	161 582 205	161 582 215	4.070	1	0
40	10	161 582 206	161 582 216	4.240	1	0
50	10	161 582 207	161 582 217	4.470	1	0

D (mm)	D1 (mm)	H (mm)	H1 (mm)	H2 (mm)	H3 (mm)	L (mm)	L2 (mm)	L3 (mm)	M	z (mm)	Inch (inch)
79	43	132	111	21	12	171	120	42	M6	126	1/2
100	51	177	148	29	14	207	150	53	M6	156	3/4
100	58	177	148	29	14	214	150	53	M6	156	1
147	72	251	207	44	21	275	205	76	M8	211	1 1/4
147	83	251	207	44	21	281	205	76	M8	211	1 1/2
147	101	251	207	44	21	288	205	76	M8	211	2

The technical data are not binding. They neither constitute expressly warranted characteristics nor guaranteed properties nor a guaranteed durability. They are subject to modification. Our General Terms of Sale apply.

Georg Fischer Piping Systems Ltd, Postfach, CH-8201 Schaffhausen/Switzerland
 Phone +41 -(0)52-631 1111
 e-mail: info.ps@georgfischer.com
 Internet: <http://www.gfps.com>