

## FOR CHLORINE AND SO<sub>2</sub> 150 LB CYLINDERS

- CORROSION RESISTANT PVC PLATFORM AND STAINLESS STEEL LOAD CELL
- WALL MOUNTED CHAINING BRACKET / TOOL RACK
- 4-20MA OUTPUT INCLUDED
- SIMPLE, RUGGED DESIGN - NO MOVING PARTS!

THE CHLOR-SCALE 150 IS DESIGNED TO WEIGH 150 LB CHLORINE AND SO<sub>2</sub> CYLINDERS USED AT WATER TREATMENT PLANTS, WELL HEADS, BOOSTER STATIONS AND VARIOUS INDUSTRIAL PLANTS. A LOW OVERALL HEIGHT OF 1-5/8" ALLOWS CYLINDERS TO BE EASILY ROLLED ON AND OFF WITHOUT LIFTING, AND A WALL MOUNTED CHAINING BRACKET PROVIDES THE SAFEST POSSIBLE INSTALLATION BY SECURING CYLINDERS TO THE BUILDING STRUCTURE ITSELF.

BECAUSE THE CHLOR-SCALE 150 HAS AN ALL PVC PLATFORM WITH CORROSION RESISTANT FASTENERS AND FITTINGS, YOU CAN FORGET ABOUT CORROSION NORMALLY ASSOCIATED WITH CHLORINE AND SWEATING CYLINDERS. OUR INCREDIBLY SIMPLE "PIVOTED PLATFORM" DESIGN HAS NO MOVING PARTS. THIS MEANS THAT THERE ARE NO FLEXURES, LEVERS OR MECHANICAL LINKS THAT ARE SUSCEPTIBLE TO CORROSION, BENDING OR BREAKING.

OUR SOLO® G2 DIGITAL WEIGHT INDICATOR CAN INDEPENDENTLY MONITOR ONE OR TWO CYLINDERS AND INCLUDES A 4-20MA OUTPUT SIGNAL FOR EACH SCALE TO ALLOW REMOTE MONITORING. HOUSED IN A NEMA 4X ENCLOSURE, THE SOLO G2 IS COMPLETELY PROTECTED AGAINST HARSH ENVIRONMENTS SUCH AS CHEMICAL ROOMS AND OUTDOOR INSTALLATIONS. START-UP AND NORMAL OPERATION ONLY REQUIRES THE SIMPLE ADJUSTMENT OF A ZERO/TARE ADJUST KNOB LOCATED WITHIN EASY REACH BUT OUT OF NORMAL LINE-OF-SITE TO REDUCE TAMPERING. THE CHLOR-SCALE 150 COMES PRE-CALIBRATED AND IN MOST INSTANCES INSTALLATION CAN EASILY AND QUICKLY BE ACCOMPLISHED BY PLANT PERSONNEL.



THE SOLO G2 DIGITAL WEIGHT INDICATOR IS SIMPLE TO OPERATE AND INCLUDES 4-20MA OUTPUTS



WALL MOUNTED CHAINING BRACKET INCORPORATES TOOL HOOKS TO STORE CYLINDER CHANGE-OUT TOOLS.



OVER 35 YEARS OF EXPERIENCE

# ELECTRONIC CHLOR-SCALE 150® WITH SOLO® G2

## MODELS AND ORDERING INFORMATION

UNITS COME STANDARD WITH PVC PLATFORM(S), LOAD CELL(S) WITH 10 FEET OF CABLE, CHAINING BRACKET/TOOL RACK(S), AND SOLO G2™ DIGITAL INDICATOR WITH 4-20MA OUTPUT SIGNAL(S). FOR CABLE LENGTHS OVER 10 FEET, ADDITIONAL CHAINING BRACKETS OR ALARM RELAYS, PLEASE CONSULT FACTORY AT (800) 893-6723. FOR MORE INFORMATION ON SOLO G2 DIGITAL INDICATOR, SEE SOLO G2 BULLETIN, No. 516.

MODEL	NUMBER OF CYLINDERS	CAPACITY	STANDARD INCREMENTS	SHIPPING WEIGHT
GR150-1	1	300 LBS	0.2 LBS	21 LBS
GR150-2	2	600 LBS	0.2 LBS	50 LBS
<b>METRIC</b>				
GR100K-1	1	150 KG	0.1 KG	10 KG
GR100K-2	2	300 KG	0.1 KG	23 KG

FOR OTHER INCREMENTS, CONSULT FACTORY

ELECTRONIC CHLOR-SCALE 150 ACCOMMODATES MOST INTERNATIONAL CYLINDER SIZES. EXAMPLE 33KG., 68KG., 70KG., 100KG.

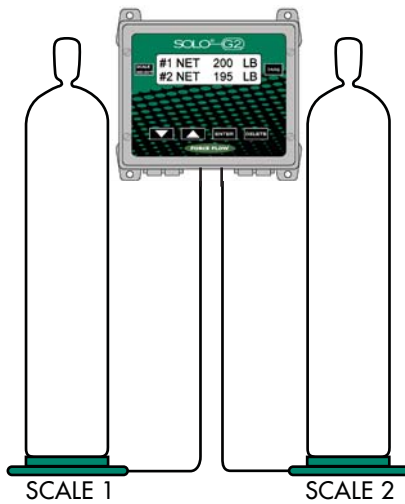

MODEL GR150-2

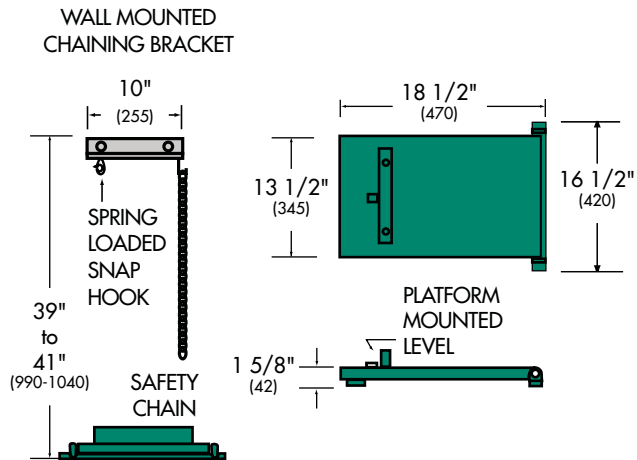

DIMENSIONS: INCHES (MILLIMETERS)

TYPICAL SPECIFICATION FOR ELECTRONIC SCALE FOR 150 LB. CHLORINE AND SO2 CYLINDERS	
A QUANTITY OF ____ CHLORINE/SO2 SCALES SHALL BE PROVIDED AND SHALL BE OF THE ELECTRONIC READOUT/ELECTRONIC LOAD CELL TYPE. SCALE PLATFORM(S) SHALL BE CONSTRUCTED OF NON-CORROSIVE PVC PLASTIC AND SIZED TO ACCEPT ONE (1) 150 LB. (68 KG) CYLINDER. SCALE PLATFORM SHALL MEASURE 13-1/2" X 18-1/2" (345MM X 470MM). INDICATOR SHALL INDEPENDENTLY MONITOR ____ (1 OR 2) CYLINDER(S).	
SCALE SHALL BE OF THE SINGLE LOAD CELL DESIGN. WEIGHT SHALL BE TRANSFERRED VIA A PIVOTED PLATFORM TO A SINGLE STAINLESS STEEL CANISTER LOAD CELL OF THE ELECTRONIC STRAIN GAUGE TYPE. LOAD CELL SHALL BE MECHANICALLY SEALED WITH VITON O-RINGS. POTTED-TYPE LOAD CELLS SHALL NOT BE ACCEPTED.	
FLEXIBLE CABLE SHALL CONNECT LOAD CELL TO INDICATOR TO ALLOW EASY REMOTE INSTALLATION OF THE READOUT. CABLE LENGTH SHALL BE ____ FEET (10'/3M STANDARD). CYLINDER CHAINING BRACKET SHALL BE WALL-MOUNTED AND USE A DOUBLE COIL CHAIN AND A SPRING LOADED SNAP HOOK TO SECURE CYLINDER. CHAINING BRACKET SHALL HAVE AN INTEGRAL TOOL RACK FOR STORING CYLINDER CHANGE-OUT TOOLS.	
INDICATOR SHALL CARRY CE MARKING AND SHALL BE HOUSED IN A NEMA 4X, UL APPROVED ENCLOSURE. LCD READOUT SHALL HAVE BACKLIGHTING FOR READABILITY IN LOW LIGHT CONDITIONS. NUMERICAL DISPLAY SHALL HAVE 6 FULL ACTIVE DIGITS AND ADJUSTABLE BAR GRAPH DISPLAY SHALL READ 0-100%. TARE ADJUST SHALL BE ACCOMPLISHED USING A KEYPAD AND INDICATOR SHALL OUTPUT NET WEIGHT VIA A 4-20 MA SIGNAL FOR REMOTE MONITORING.	
SCALE SHALL CARRY A FULL FIVE (5) YEAR FACTORY WARRANTY. "LIMITED" WARRANTIES SHALL BE CONSIDERED UNACCEPTABLE.	
FULL SCALE ACCURACY SHALL BE BETTER THAN 1%. SCALE SHALL BE CHLOR-SCALE® 150 WITH ELECTRONIC SOLO® G2 DIGITAL INDICATOR, MODEL GR150-____, AS MANUFACTURED BY FORCE FLOW / FLOQUIP, 2430 STANWELL DR, CONCORD, CA 94520 USA (WWW.FORCEFLOW.COM), OR EQUAL.	
<b>OPTIONAL FEATURE</b>	SET POINTS SHALL ACTIVATE ____ 0.5A DRY CONTACT RELAYS.